

# PREMET® *online*

## AUTOMATED COMBUSTION ANALYSIS

- A permanently installed system to control motor performance
- For main engines and auxiliary engines
- For diesel and gas engines
- For engines up to 20 cylinders
- Pressure measurement range 0-250 bar

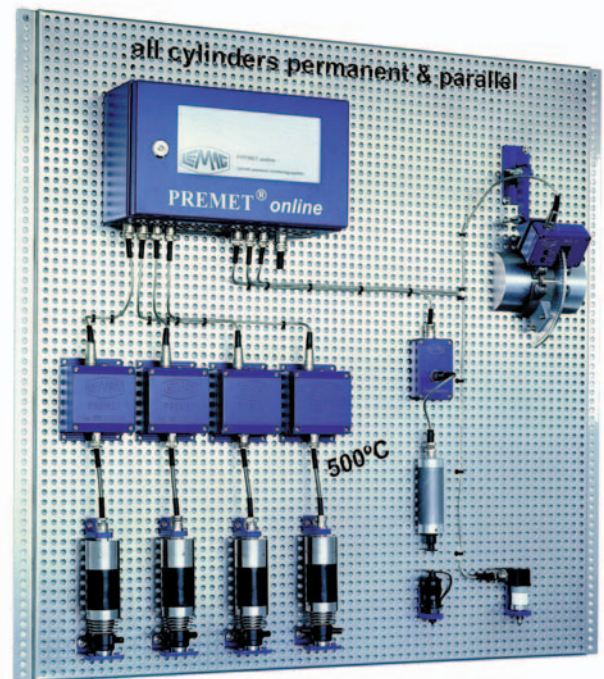

**PREMET® *online* – a permanently installed system to control engine performance**

### Online measurement

LEMAG PREMETS® *online* is a permanently installed system developed for measurement of cylinder pressure on diesel and gas engines. In this system each cylinder is equipped with a LEMAG PREMETS® Pressure Sensor. The sensors are attached to the existing indicator valves and they all measuring the cylinder pressure at the same time. This *online* information is then transmitted to a central computer for analysis.

It is also possible to mount the Pressure Sensors directly in the indicator channels. In this case it is necessary to consult LEHMANN & MICHELS for technical details.

For crankshaft angle measurement it is recommended to use LEMAG Multiscan Sensor (MS-Sensor). The MS-sensor is a crank angle sensor custom manufactured according to each special shaft diameter for easy installation.

The MS-sensor produces a signal 360 times per revolution. This 1 degree crank angle resolution enables perfect recording and compensation for the changing angular velocities of the engine.

The cylinder pressure values are then transmitted to the LEMAG Engine Information Sampling Unit. This calculator verifies the plausibility of the measured values and relates the pressure values to the current crankshaft position. After transmission of this data to the PC, all major indicators of engine performance can be analysed easily on the computer screen.

The LEMAG PREMETS® *online* monitors:

- Mean indicated pressure
- Max. cylinder pressure
- Indicated power
- Torsional vibration
- Expansion pressure
- Main trend function

Subject to change without notice

# PREMET® *online*

## LEMAG PREMETS® *online* for the main engine

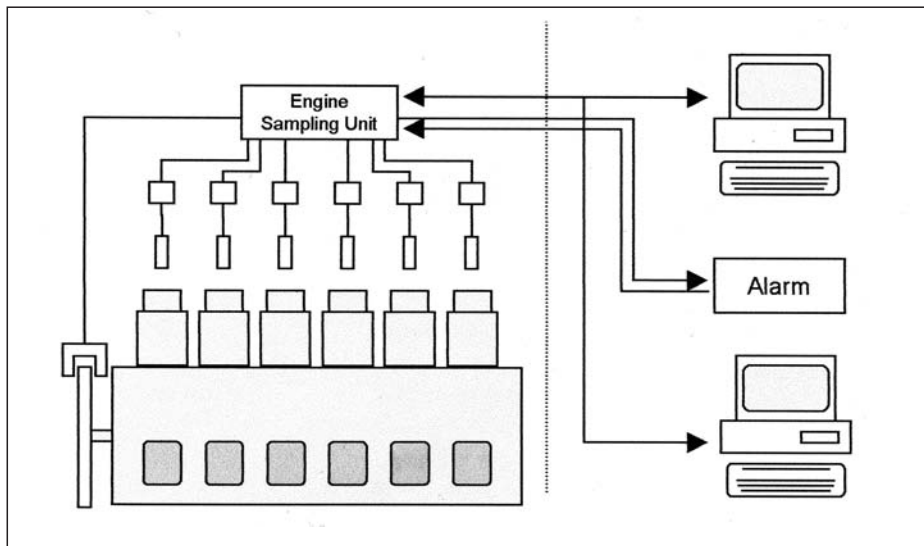

The drawing shows an example system arrangement for a six cylinder main engine. The Multiscan Sensor Wheel and the MS-Sensor are pictured on the left side of the engine.

### PREMET Multiscan Sensor Wheel

The MS-Sensor measures crankshaft rotation in 1° steps. The information is further analysed by the software of the engine sampling unit. The advantage to tooth profile resolution on the flywheel is more direct recording of engine angular velocities.

Expenditure on installation is minimised by manufacturing the MS-Sensor Wheel according to the shafts diameter. Drilling of the flywheel or shaft for installation is not necessary.

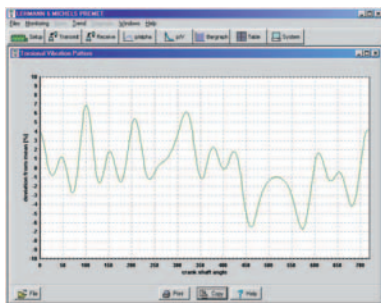

The picture shows the torsional vibration pattern of the crankshaft during 720° (two complete revolutions).

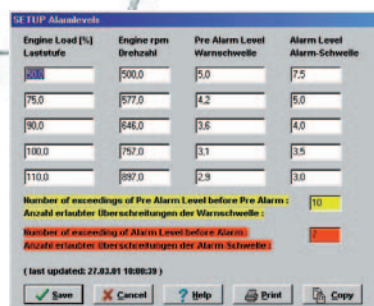

Engine Load [%] Laststufe	Engine rpm Drehzahl	Pre Alarm Level Warnschwelle	Alarm Level Alarm-Schwelle
80.0	500.0	5.0	7.5
75.0	577.0	4.2	5.0
90.0	646.0	3.6	4.0
100.0	757.0	3.1	3.5
110.0	897.0	2.9	3.0

Number of exceedings of Pre Alarm Level before Pre Alarm: 10  
Anzahl erlaubter Überschreitungen der Warnschwelle: 10

Number of exceedings of Alarm Level before Alarm: 5  
Anzahl erlaubter Überschreitungen der Alarm-Schwelle: 5

(last updated: 27.02.01 10:00:39)

The limits to measure torsional vibration change can be individually defined in the software.

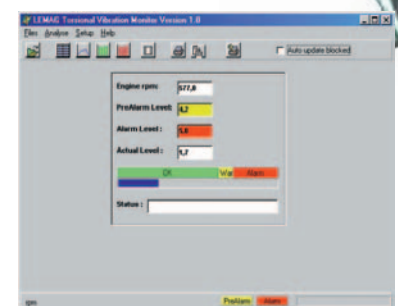

The system warns automatically if the vibration change exceeds the given limits.

Subject to change without notice



Since 1911  
Measuring  
Instruments

# PREMET® *online*

PREMET® *online* offers you the possibility to control your engine performance continuously

The information gathered from the pressure sensors is collected by the PREMET engine sampling unit to be further analysed by PREMET® *online* software. This software gives you a wide variety of diagrams delivering important and accurate information relating to the engine's performance.

By using PREMET® *online* you are now in a position to recognise the most common problems on diesel and gas engines before they cause major break downs, expensive repairs or time schedule delays. After a brief look at the PC screen you are in most cases able to tell immediately why the engine, or some of its cylinders, are not producing the expected power.

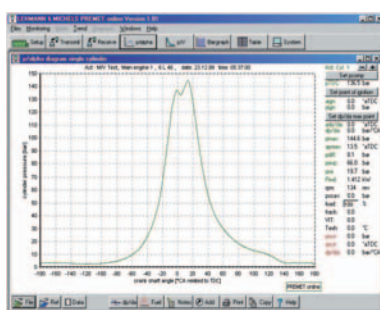

p-alpha diagram single cylinder

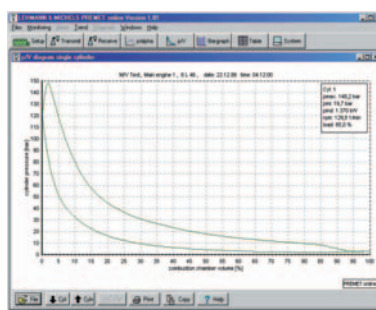

p/V diagram single cylinder

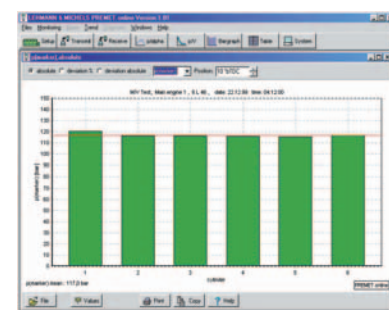

Bargraphs

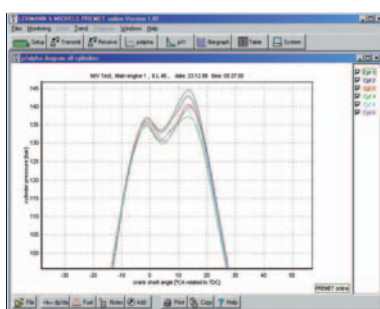

p-alpha diagram all cylinders

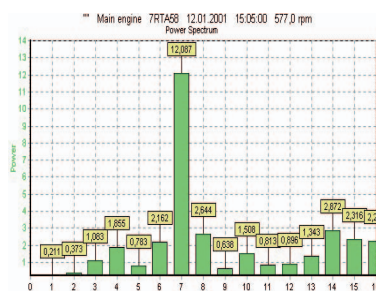

Torsional vibration spectrum

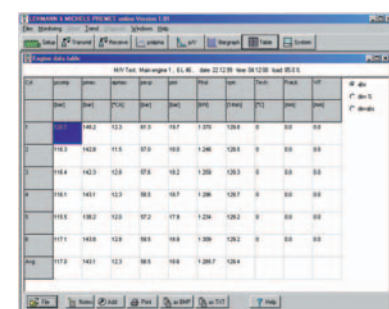

Engine data table

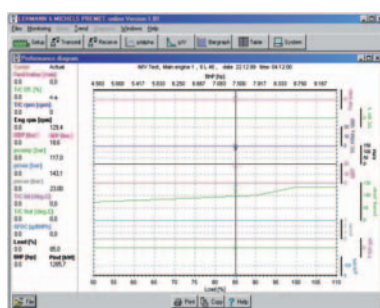

Engine performance diagram

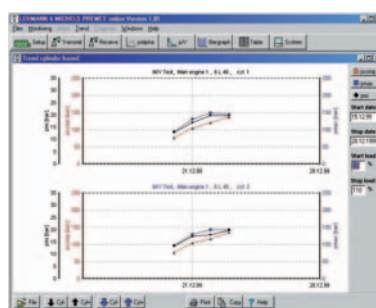

Trend function

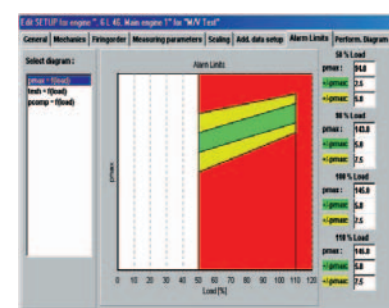

Alarm set up

Subject to change without notice



Sales & Service Center Rellingen  
**LEHMANN & MICHELS GmbH**

Siemensstraße 9 · 25462 Rellingen · Germany

Tel. +49 4101 5880 0 · Fax +49 4101 5880 129 · www.lemag.de · lemag@lemag.de



Since 1911  
Measuring  
Instruments

# PREMET® *online*

## Technical data of system components:

Cylinder Pressure Sensor **PREMET® *online*** type 250/2/IC/1AA:

Measuring range:	Up to 250 bar
Measuring time:	Up to 2 h daily, 24 h once a month in heavy fuel working
Precision:	Class 1,6 % fs
Mounting:	Indicator valve (other applications on request)

Engine Sampling Unit **PREMET® *online*** type 250/2-24/230/1AA:

Type:	High speed industrial calculator
Temperature:	60 °C max.

Multiscan sensor **PREMET® *online***:

Type:	Custom made Crank Angle Sensor
Precision:	Real 1° resolution
Measuring type:	Opto-electronic

Pscav Sensor **PREMET® *online*** type 05/2-24/XX/1AA (optional):

Type:	4-20 mA Pressure Sensor
Precision:	Class 1,6 % fs
Measuring range:	0-4 bar

Fuel Pressure Sensor **PREMET® *online*** type 2000/FC/1AA (optional):

Measuring range:	Up to 2000 bar
Connection:	Cone connection

Torsional vibration measurement:

Type:	Multiscansensor <b>PREMET® <i>online</i></b>
Engine Type:	under 300 rpm, other engine types on request
Measuring time:	24 hours a day

108/12/2004/E

Subject to change without notice



Sales & Service Center Rellingen  
**LEHMANN & MICHELS GmbH**

Siemensstraße 9 · 25462 Rellingen · Germany

Tel. +49 4101 5880 0 · Fax +49 4101 5880 129 · [www.lemag.de](http://www.lemag.de) · [lemag@lemag.de](mailto:lemag@lemag.de)